

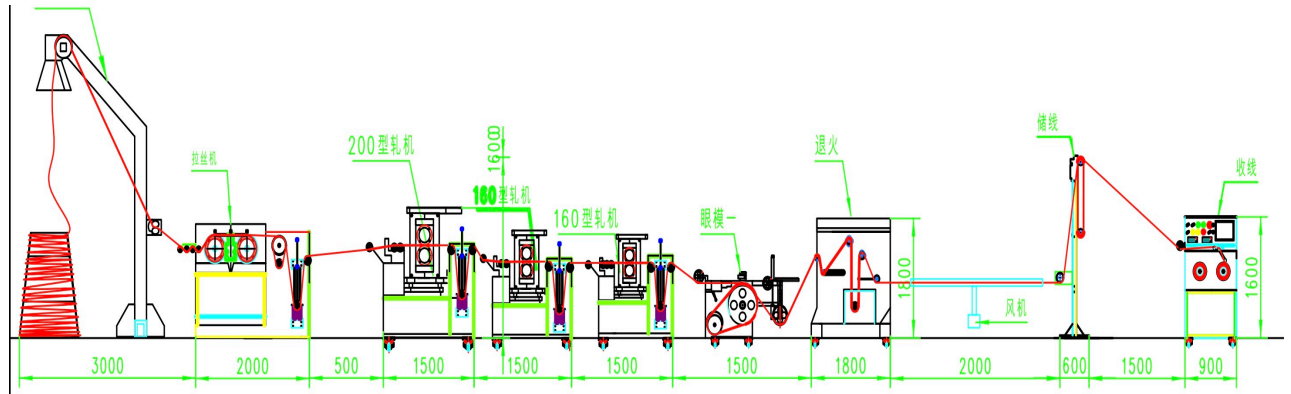

Suzhou Newlead Augmented Intelligence Equipment Co.Ltd
NEWLEAD TRADE SUZHOU CO.,LTD

New advanced PV Busbar Rolling Mills and annealing machine



Equipment components

1. Payoff
 2. 9D Drawing machine, motor 22KW
 3. Rolling mills No 1:
 4. Rolling mills No 2:
 5. 3 Rolling mills No 3
 6. Flat wire polishing drawing
 7. Annealing:
 8. Dancer
 9. Take up (Dual spools):
8. Layout: 20M*1.5M*2M
 9. Installation power: 70KW

PV Busbar Tinning machine

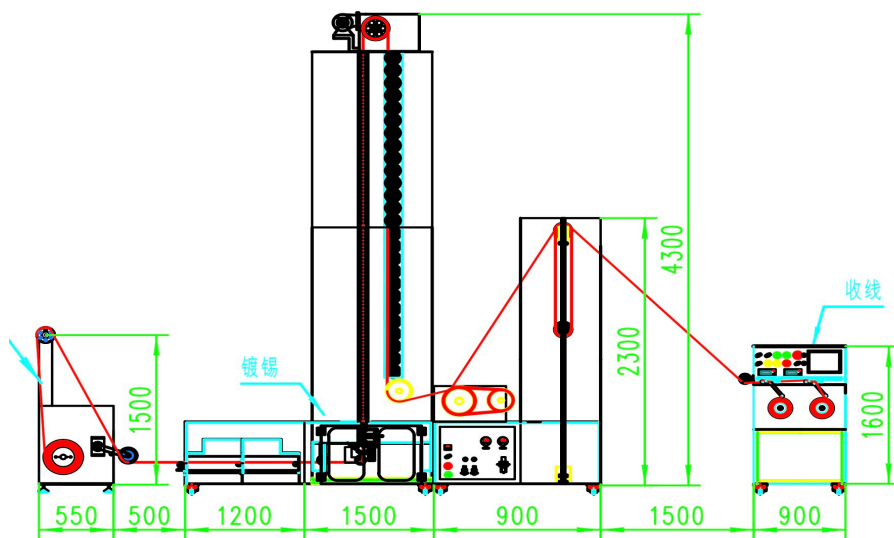

Equipment components



Office: No 2401 Jingchang TECH park, CaiXiang road, Suzhou city. Whatsapp: 008618913191585
 Factory: No 50 Jin san jiao north road, wujing district, Changzhou city www.newleadgroup.com



Suzhou Newlead Augmented Intelligence Equipment Co.Ltd
NEWLEAD TRADE SUZHOU CO.,LTD

- 1.Motor drive payoff:
2. Solder resist:
- 3.Tinning:
- 4.Dancer
- 5.Take up(Dual spools)
- 6.Layout:8M*1.5M*4.5M
- 7.Installation power:15KW

Note

1.Electrical system and others	<u>Setting remotely (with WIFI function)</u> 	Reasonable layout with safety signs
	<u>Aviation plug (user only need connect the Power Supply and the aviation plugs)</u> 	

2.Main brand

No	Name	Brand
1	Inverter/Servo	Inovance
2	PLC/touch screen	Inovance
3	Low voltage electrical apparatus	Schneider
4	Motor	Wannan
5	Bearing	NSK

3.Spare parts offer



Suzhou Newlead Augmented Intelligence Equipment Co.Ltd
NEWLEAD TRADE SUZHOU CO.,LTD

Spare parts for New advanced PV ribbon rolling, annealing and tinning machine,1-2-3 are Wearing parts in Two years.4-5-6-7 are special design, Occasionally broken in 5 years.(Not including in the offer)

1	PVRAT/P	Annealing Pass wire pulleys	50		
2	PVRAT/GW	Tension control guide wheel	30		
3	304P	Tinning pass wire pulleys	10		
4	PVRAT/AB	Annealing carbon brush	8		
5	PVRAT/CW	Annealing copper wheel	2		
6	PVRAT/GW	Annealing carbon brush copper wheel	2		
7	PVRAT/R	Roller	3		
Total					

4.Capacity

Diameter	Kg/h
0.30mm*6.0mm	50kg
0.35mm*6.0mm	55kg

Others.

1.Direction: right equipment operation

2 Paint:Paint after rustproof production according to NEWLEAD standards or according to user's requirement.

3. The period of guarantee:

12 months for mechanical part (excluding the consumables) after the shipment;

6 months for electrical parts after the shipment

Office:No 2401 Jingchang TECH park ,CaiXiang road ,Suzhou city. Whatsapp:008618913191585
 Factory:No 50 Jin san jiao north road,wujing district,Changzhou city www.newleadgroup.com



Suzhou Newlead Augmented Intelligence Equipment Co.Ltd
NEWLEAD TRADE SUZHOU CO.,LTD

Permanent maintenances (charge)

4. Commissioning

A .Installation and debugging charge :Our company will arrange technicians to buyer's factory to help buyers to install machines and teach them how to produce the foam sheet& tubes. Two round-trip tickets ,hotel ,and food will be in buyer's account ,And the salary of 100 US dollars per person per day (if they need to be quarantined locally, including the time of quarantine in your country and China)

B. The buyer supplies all the material for the test, such as Bobbin(Drum), gear oil, Lubricant oil, Dies, Butt welder, Raw Material, Air compressor, test equipment ,etc. are excluded.

C. The power supply, compressed air source and water source shall be connected to the points designated by the supplier near the equipment by the customer. The customer is responsible for fixing the equipment according to the layout, and is responsible for the wiring and grounding from the workshop power line to the electrical cabinet.

5. Maintenance: NEWLEAD offers long-distance mechanical support for free; if the engineers are needed to be in the buyer's company for maintenance, the buyer offers flight ticket (SHANGHAI), board and lodging. (USD100/DAY)

6. Wooden pallets packing for shipping

Note:

All information above are carefully checked, our company reserve explain right if any printing mistake or any misunderstanding.

Another: Sorry for noting no advanced notice for the techniques improvement or upgrade on the machine; any change on the appearance or color, please refer to the real object.